

Фрезер СМТ за дърво профилен прав, с лагер и сменяема
пластина ф 19х48.3/100 мм, ф 12 мм, 656

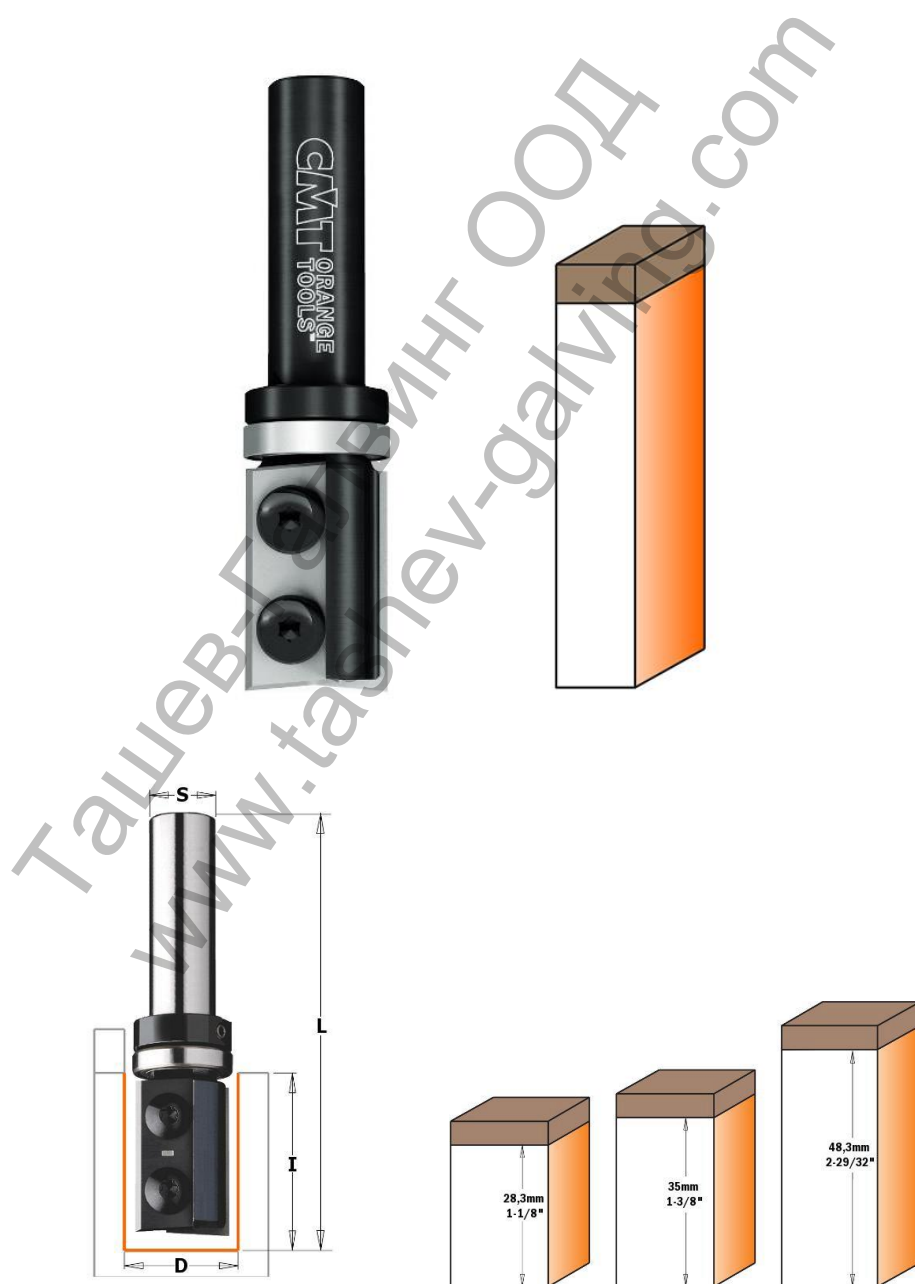

This bit type is equipped with top bearing for template use. For finishing, routing and grooving in board materials (laminated chipboards, MDF) and hardwood. For use on portable routers or CNC machining centres.



Insert carbide.



Two cutting edges



Right-hand rotation



Tool with bearing

D	I	L	ORDER NO.	ORDER NO.	ORDER NO.
mm	mm	mm	S=Ø8mm	S=Ø12mm	S=Ø12,7mm
16	35	80	656.160.11		
19	28,3	69	656.190.11		
19	28,3	79			656.691.11
19	48,3	100		656.692.11	656.693.11

Продукт: [Фрезер CMT за дърво профилен прав, с лагер и сменяема пластина ф 19x48.3/100 мм, ф 12 мм, 656](#)

Категория: [Консумативи за фрези и обертфрези](#)

Бранд: [CMT](#)

Категория бранд: [Фрезер CMT](#)

Ташев-Галвинг ООД
www.tashev-galvink.com